

LOW DENSITY RESIDENTIAL DRIVEWAYS

GRADE BREAK 15% MAX.
FOR SAG CHANGE IN
SLOPE.

GRADE BREAK 10%
MAX. FOR CREST
CHANGE IN SLOPE.

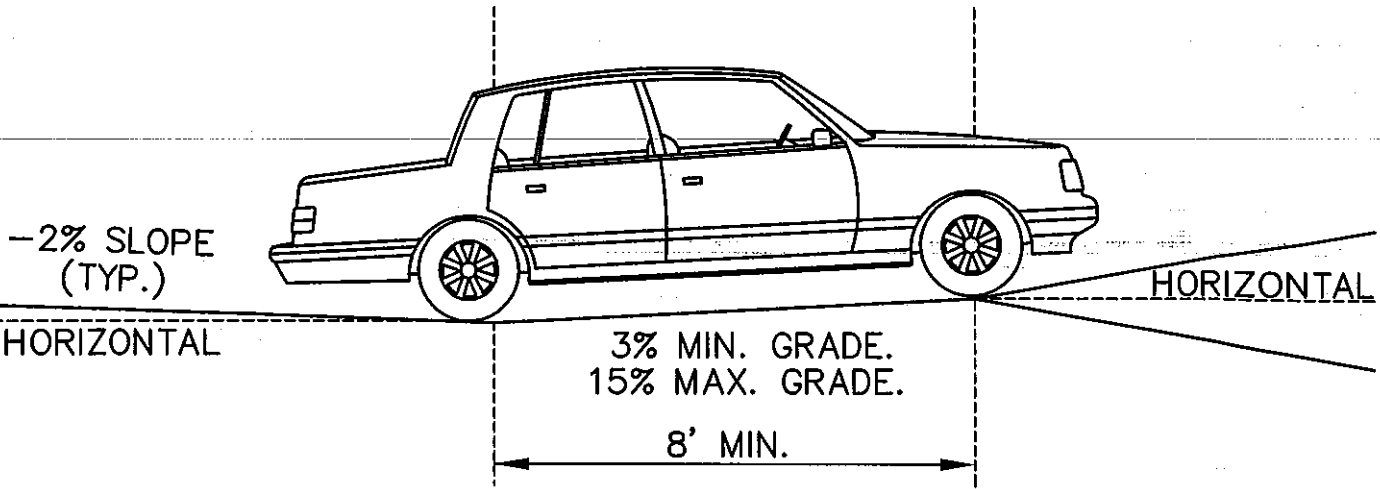

HIGH DENSITY RESIDENTIAL & COMMERCIAL DRIVEWAYS

GRADE BREAK

GRADE BREAK * 8%
MAX. CHANGE IN
SLOPE.

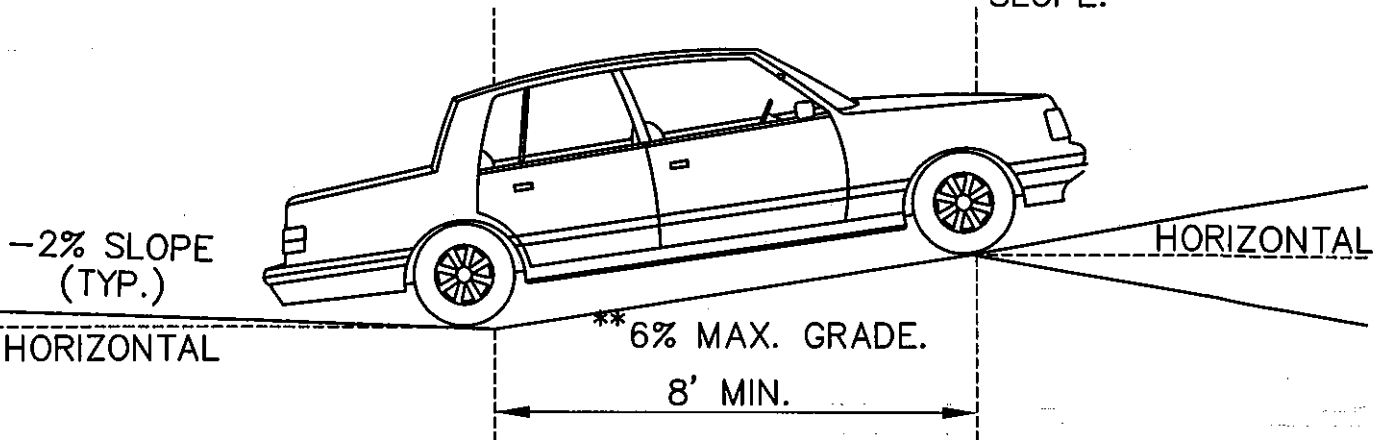

- * DRIVEWAY GRADES NOT TO EXCEED 8%
- ** THE DISTANCE BEGINS AT THE BACK OF WALK

CITY OF SAN BUENAVENTURA

PUBLIC WORKS DEPARTMENT
ENGINEERING DIVISION

DESIGNED BY: N.L.
DRAWN BY: D.T.
CHECKED BY: J.S.
APPROVED BY: [Signature]
TRANSPORTATION ENGINEER

ACCESS GRADES

APPROVED BY [Signature]
CITY ENGINEER R.C.E. 37064

DATE 6-5-01

STD. DET. NO.

129

SHEET
1 of 1